

This article was downloaded by:

On: 23 January 2011

Access details: *Access Details: Free Access*

Publisher *Taylor & Francis*

Informa Ltd Registered in England and Wales Registered Number: 1072954 Registered office: Mortimer House, 37-41 Mortimer Street, London W1T 3JH, UK



International Journal of Polymeric Materials

Publication details, including instructions for authors and subscription information:

<http://www.informaworld.com/smpp/title~content=t713647664>

Scanning Electron Microscopy Studies on Failure of Natural Rubber

P. K. Pal^a; A. K. Bhowmick^a; S. K. De^a

^a Rubber Technology Centre, Indian Institute of Technology, Kharagpur, West Bengal, India

To cite this Article Pal, P. K. , Bhowmick, A. K. and De, S. K.(1982) 'Scanning Electron Microscopy Studies on Failure of Natural Rubber', International Journal of Polymeric Materials, 9: 2, 139 – 149

To link to this Article: DOI: 10.1080/00914038208077974

URL: <http://dx.doi.org/10.1080/00914038208077974>

PLEASE SCROLL DOWN FOR ARTICLE

Full terms and conditions of use: <http://www.informaworld.com/terms-and-conditions-of-access.pdf>

This article may be used for research, teaching and private study purposes. Any substantial or systematic reproduction, re-distribution, re-selling, loan or sub-licensing, systematic supply or distribution in any form to anyone is expressly forbidden.

The publisher does not give any warranty express or implied or make any representation that the contents will be complete or accurate or up to date. The accuracy of any instructions, formulae and drug doses should be independently verified with primary sources. The publisher shall not be liable for any loss, actions, claims, proceedings, demand or costs or damages whatsoever or howsoever caused arising directly or indirectly in connection with or arising out of the use of this material.

Scanning Electron Microscopy Studies on Failure of Natural Rubber

P. K. PAL, A. K. BHOWMICK and S. K. DE

Rubber Technology Centre, Indian Institute of Technology, Kharagpur 721302, West Bengal, India

(Received September 15, 1981)

The changes in failure mode of natural rubber reinforced with HAF black (N 330) and vulcanized by two systems (conventional and efficient vulcanization) have been studied by scanning electron microscopy (SEM). The effect of vulcanization system on the failure mode is not pronounced. However, effect of reinforcing filler is quite distinct. In the case of fracture by tension and tear, it is observed that with the addition of filler tear lines gradually start deviation resulting curved tear paths which, in many instances, are parabolic in nature. Likewise in abrasion, change in structure of the ribs with the addition of filler is observed. In flex failure, gradual addition of filler causes change from ductile failure to brittle failure for both conventional and EV systems. EV mixes show more cracks and less flow on the surface leading to poorer flexing strength.

1. INTRODUCTION

Reinforcement of an elastomer means improvement of failure properties like tensile, tear, abrasion and flexing. Reinforcement is achieved by incorporation of carbon black and silica. Kraus,¹ Medalia,² Dannenberg and Brennan,³ Studebaker⁴ and Voet⁵ have extensively reviewed reinforcement of rubber by carbon black. In our earlier communication,⁶ we have shown changes in network structure and physical properties on increasing addition of carbon black. In this communication, SEM studies of failure surfaces generated under tensile, tear, flexing and abrasion modes of failure have been undertaken for both conventional and EV systems on introduction of 5 and 40 phr HAF carbon black. Correlation between nature of failed or damaged zone and different physical properties has been analysed. Such relations could result in better understanding of the mechanism of reinforcement by filler.^{7 10}

TABLE I
Formulations of the mixes

Mix no.	A	B	C	D	E	F
Natural rubber ^a	100	100	100	100	100	100
Zinc oxide	5	5	5	5	5	5
Stearic acid	2	2	2	2	2	2
HAF black (N 330)		5	40	—	5	40
Processing oil		0.5	4		0.5	4
CBS ^b	0.6	0.6	0.6	3.5	3.5	3.5
Sulfur	2.5	2.5	2.5	0.5	0.5	0.5
Optimum cure time (min)	13	12	11	19	15	10

^a Natural rubber, crumb grade, obtained from the Rubber Research Institute of India, Kerala.

^b N-cyclohexyl benzothiazyl sulfenamide.

2. EXPERIMENTAL PROCEDURE

Table I shows the formulations of the mixes studied with respective optimum cure times. The details of preparation of the vulcanizates are described in the previous publication.¹¹ The compounds were vulcanized at respective optimum cure times, determined by Monsanto Rheometer (R-100) at 150°C.

Tensile and tear testing were carried out in a 'Zwick' tensile testing machine as per ASTM D 412-51T and D 624-48 respectively at room temperature (30°C). The abrasion test was carried out at room temperature in a Croydon-Akron abrader (BS 903, Pt 49: 1957 Method C) and flexing was done at 70°C by using De Mattia flexing machine according to ASTM D 430-73, Method B.

The tested specimens were vacuum coated with gold within 24 hours of testing and the coated fracture surfaces were studied using SEM model PSEM-500. SEM photographs of the tested specimens were taken within 48 hours of testing. Direction of failure and scan are shown in Figure 1. For flexing and abrasion, samples were taken from fracture surface along the dotted lines as shown in Figures 1C and 1D.

Chemical crosslink density and proportion of polysulfidic crosslinks of rubber vulcanizates were determined by swelling and chemical probes as described earlier.^{11,13}

Chemical and physical characteristics of the vulcanizates are shown in Table II.

3. RESULTS AND DISCUSSION

Results of tensile strength, tear strength, flexing endurance and abrasion resistance of 0, 5 and 40 phr black loaded EV and conventional mixes are

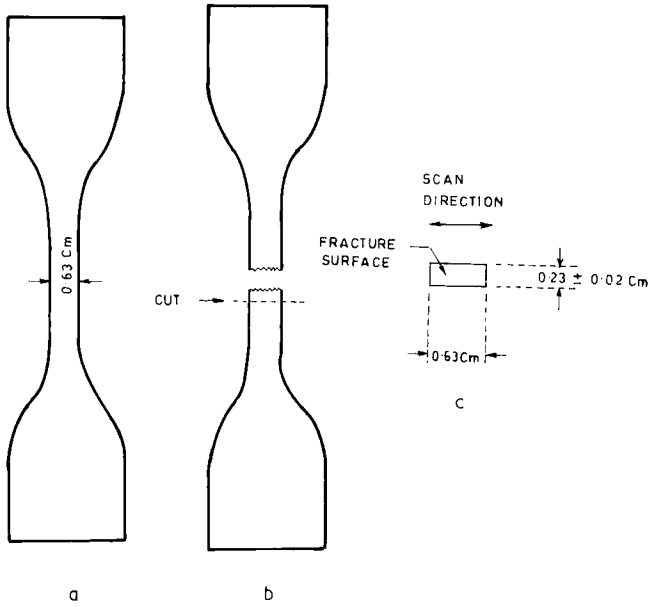

Fig. 1A

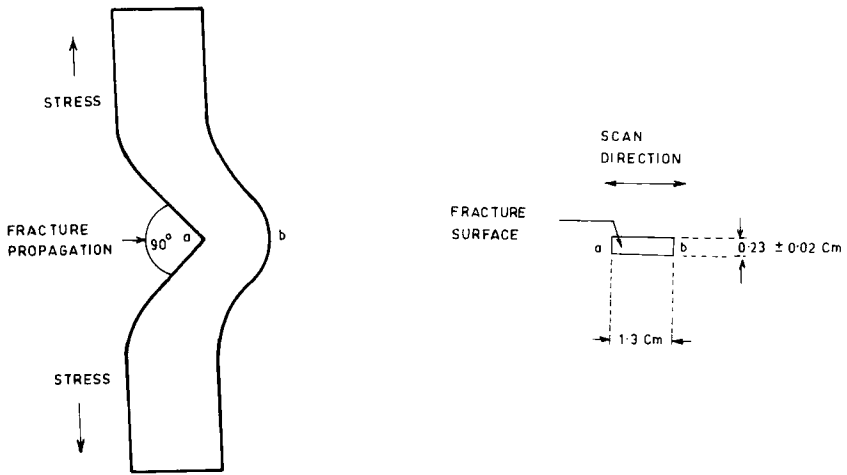

Fig. 1B

FIGURE 1—continued overleaf

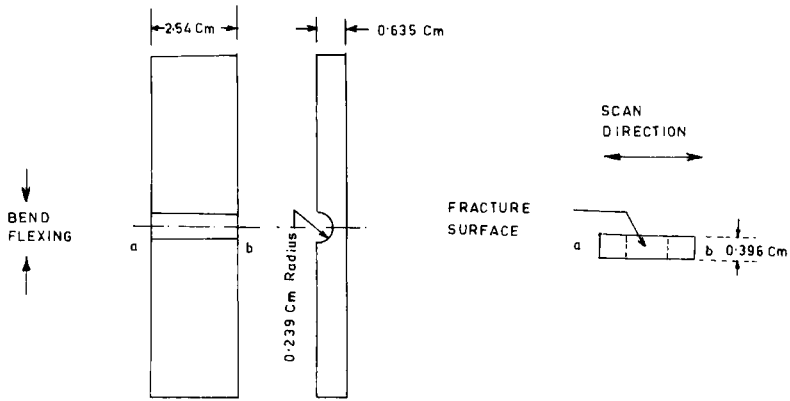

Fig. 1C

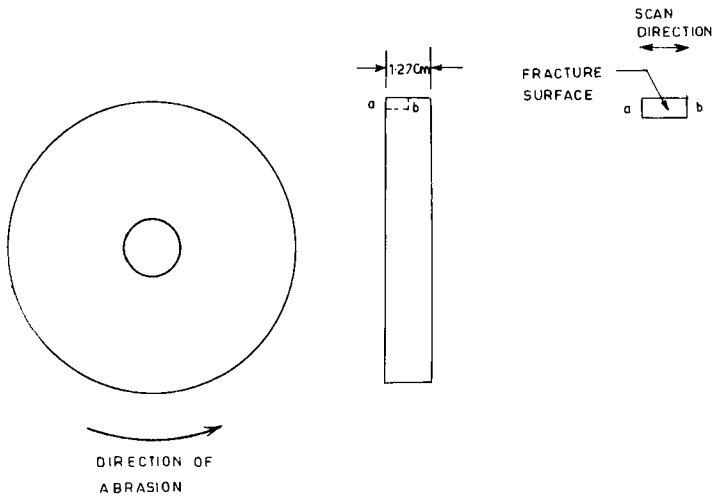

Fig. 1D

FIGURE 1 Mode of failure and scan direction of samples. A, Fracture surface after tension ; B, Fracture surface after tear ; C, Fracture surface after bend flexing ; D, Fracture surface after abrasion.

TABLE II
Physical and chemical characteristics of the vulcanizates

Property	Mix no.					
	A	B	C	D	E	F
Tensile strength (MPa)	23.7	24.2	24.3	19.6	21.0	24.0
Modulus 300% (MPa)	1.0	1.4	7.0	0.7	1.0	6.5
Tear strength ($\times 10^{-1}$ kNm ⁻¹)	2.8	3.2	8.6	2.2	2.4	8.4
Elongation at break (%)	810	760	620	785	745	630
Hardness (Shore A)	42	44	57	39	41	55
Heat build-up (ΔT °C)	5.5	6.0	19.0	8.0	8.5	21.0
Flex cracking failure (kilocycle)	192	152	99	102	67	27
Resilience (%)	85.7	81.8	54.3	75.2	73.3	53.5
Compression set (%)	57.0	57.4	69.5	38.3	38.7	42.9
Abrasion loss (cc/1000 rev.)	1.9	1.6	0.8	1.8	1.7	0.5
Total chemical crosslink						
[2Mc, chem] ⁻¹ (mmol/kg RH)	26.5	31.5	30.3	23.4	21.9	22.9
Polysulfidic crosslink (%)	61.9	68.3	63.4	20.9	21.9	22.7

recorded in Table II. With the gradual addition of filler, the tensile strength remains almost constant, the tear strength and abrasion resistance increase and the flexing endurance decreases.

SEM photographs of fracture surfaces after tensile, tear, flexing and abrasion tests are shown in Figures 2 to 5.

3.1. Tensile fracture surface

Fractured surfaces of 0, 5 and 40 phr conventional black loaded mixes have been shown in Figures 2A, 2B and 2C respectively. Figure 2A shows bright spots agglomerated along fracture paths crossing the long tear lines. The bright spots may be due to crystallite regions formed on stretching of the gum vulcanizate. With the addition of 5 phr HAF black, the bright spots disappear and the tear lines become curved (Figure 2B) and the fracture becomes brittle in nature on addition of filler. The tear lines observed on the brittle fracture surface of 40 phr black loaded conventional system are curved and form coils (Figure 2C). EV system (Figures 2D–2F) shows similar behavior, but crumbling on the surface is more.

3.2. Tear fracture surface

Figure 3A shows the fracture surface generated after tear fracture of gum conventional mix. Few tear lines with branching have been observed. Addition of 5 phr filler makes the tear lines curved which are parabolic in many

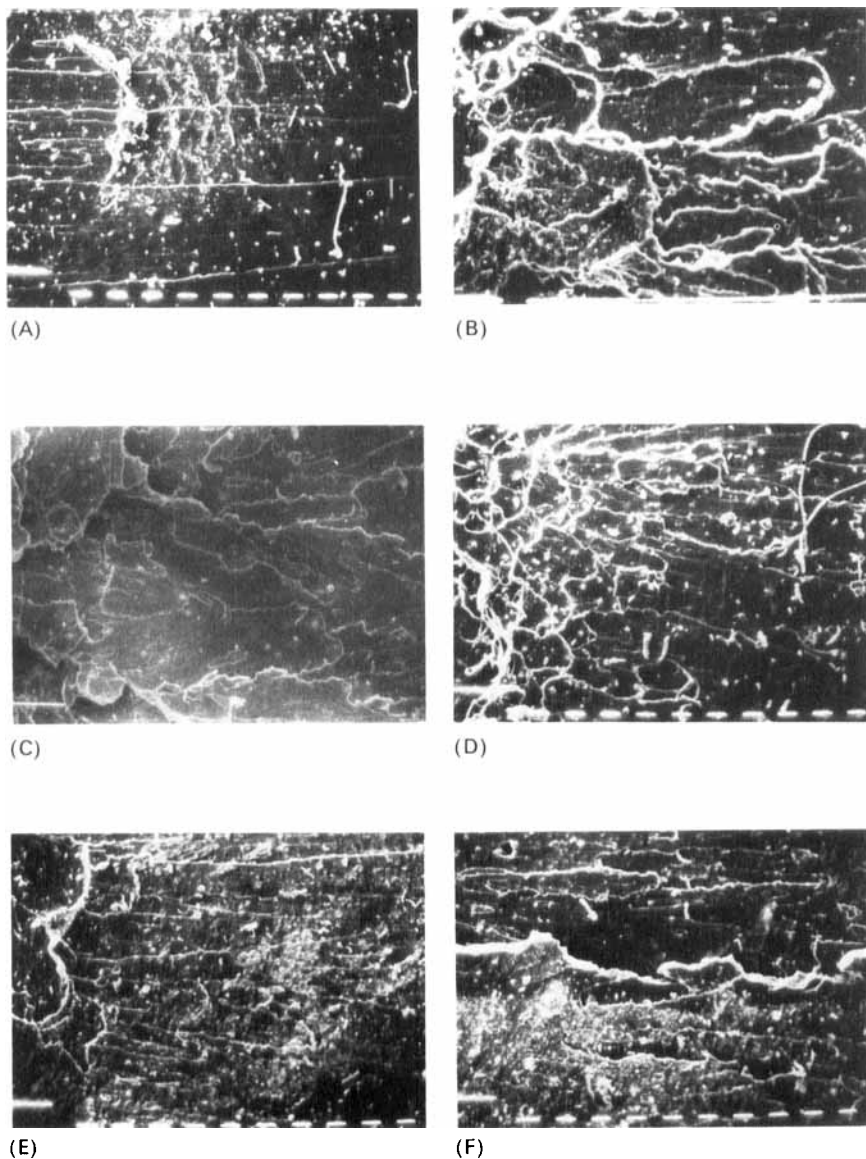
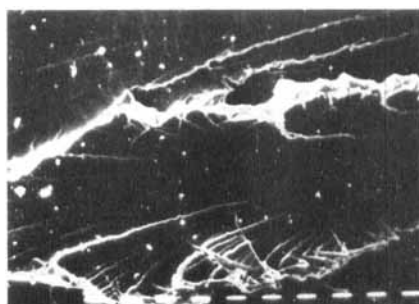

FIGURE 2 SEM photographs of tensile fracture surfaces. A, General surface with bright spots and long tear lines of mix A ($50\times$); B, Curved tear lines of mix B ($100\times$); C, General surface with curved and coiled tear lines of mix C ($50\times$); D, General surface with curved tear lines of mix D ($50\times$); E, Curved and coiled tear lines of mix E ($50\times$); F, Crumbled surface with curved tear lines of mix F ($50\times$).

instances (Figure 3B), though a few long tear lines have been observed. Figure 3C shows the fracture surface of 40 phr black loaded conventional compound. The fracture is brittle in nature and could be compared with faceted cleavage type of fracture of metals. Flow lines are not continuous and become restricted. The gradual increase of tear strength could be ascribed due to these short and curved tear lines.

EV system shows similar kind of fracture. Figures 3D and 3E show fracture surface of gum EV system. In Figure 3D many tear lines are merging at the middle of the surface and the fracture proceeds in one line from there. In Figure 3E, at higher magnification some spots are visible on the surface which act as nuclei for microfolds. Fracture surfaces (Figures 3F and 3G) of 5 and 40 phr black filled EV mixes could be compared with those of conventional mixes. But the tear lines are less curved (Figure 3F) and loose aggregates and holes were visible on the surface (Figure 3G). These factors make the tear strength poorer than that of conventional mix.



(A)

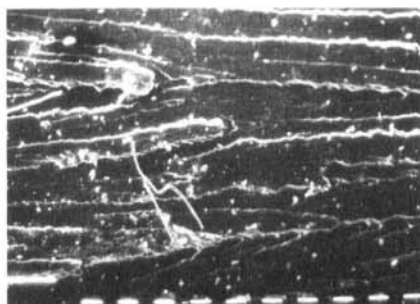

(B)

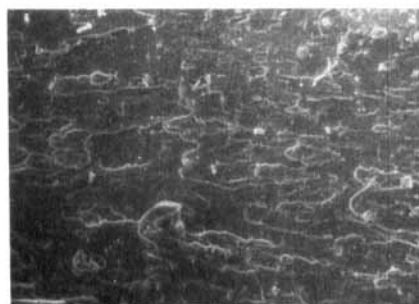

(C)

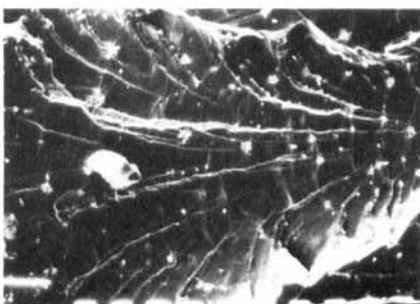

(D)

FIGURE 3 *continued overleaf*

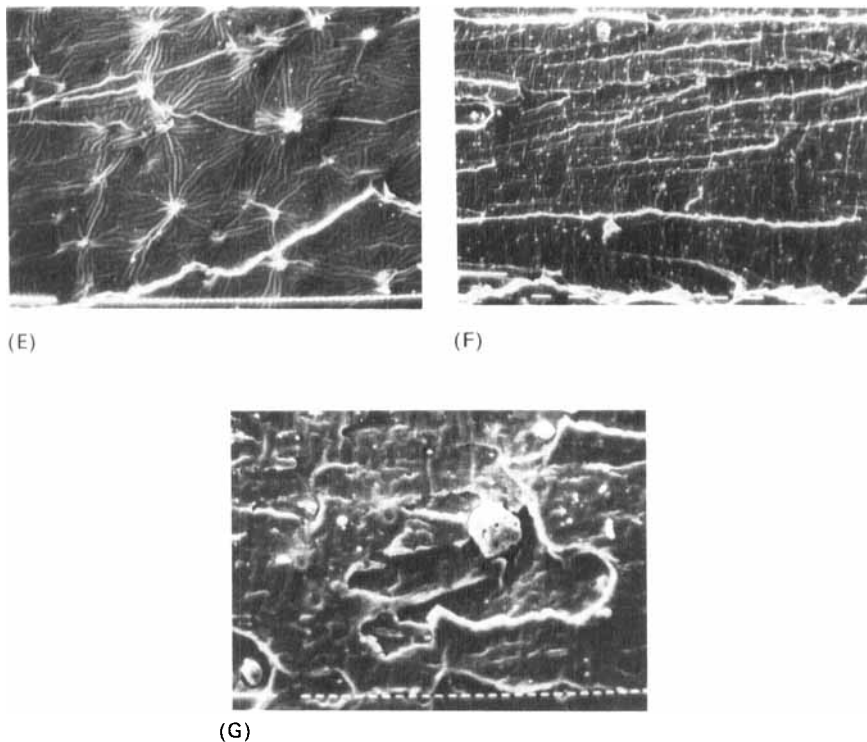

FIGURE 3 SEM photographs of tear fracture surfaces. A, General surface with branched tear lines of mix A (50 \times); B, Curved and parabolic tear lines of mix B (50 \times); C, Brittle fracture of mix C (50 \times); D, General surface showing merging of tear lines of mix D (50 \times); E, Tear lines with spots which act as nuclei for microfolds of mix D (100 \times); F, General surface of mix E (50 \times); G, Surface showing loose aggregates and holes of mix F at higher magnification (200 \times).

3.3. Abraded surface

Abrasion of natural rubber produces ribs on the fracture surface. Similar observation was reported earlier.¹² The addition of carbon black filler changes the structure of the rib. Figures 4A, 4B and 4C show the structure of ribs at 0, 5 and 40 phr black filled conventional mixes. Gum mixes show cellular structure whereas 40 phr black loaded mixes show accumulated masses. The cellular structure on the rib has been formed by the microcutting and the thick ribs are due to fatigue wear. Addition of reinforcing filler reduces the extent of microcutting by hindering the tear process. EV mixes show similar information but the flow of the matrix seem to have been restricted (Figures 4D, 4E and 4F).

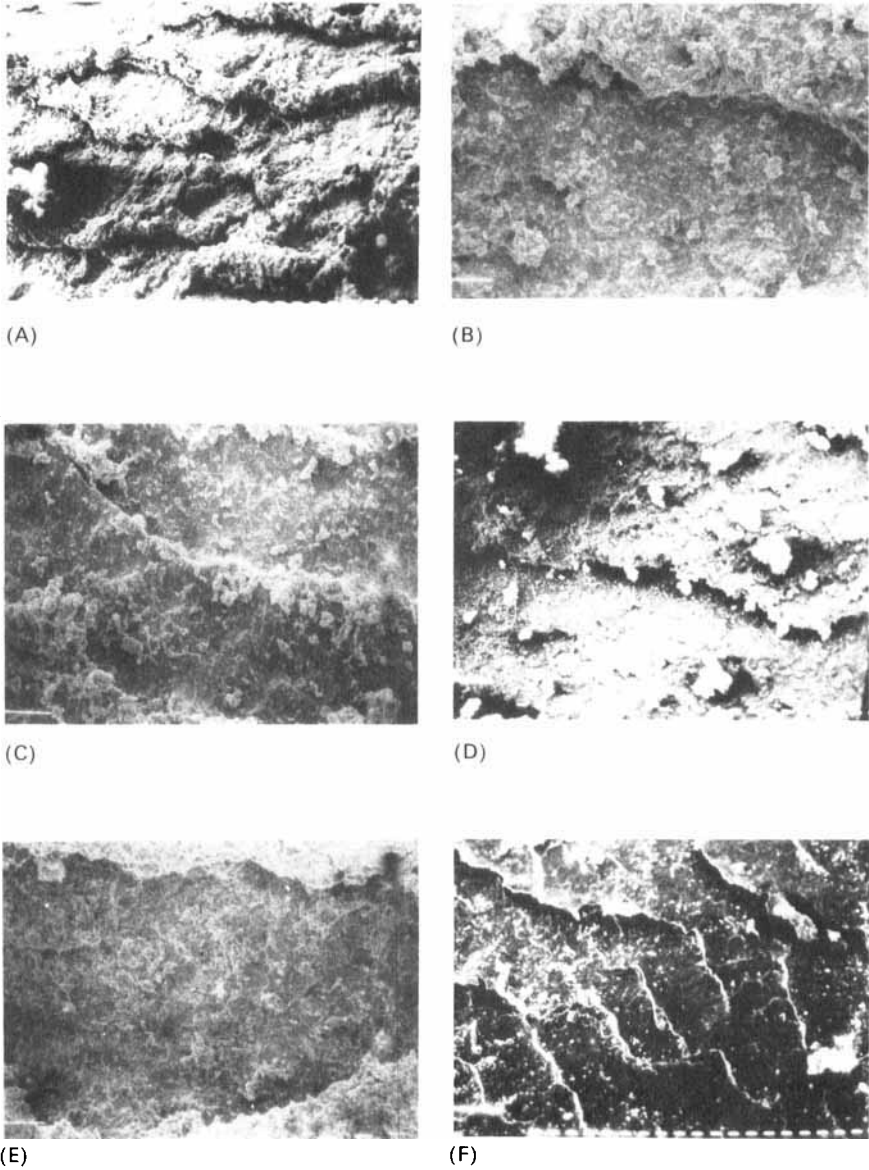
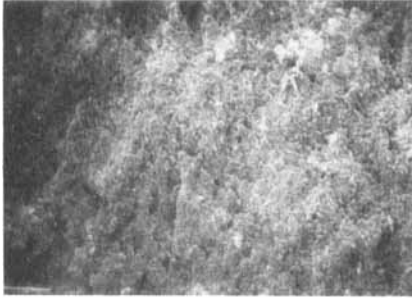

FIGURE 4 SEM photographs of abraded surfaces. A, Cellular rib structure of mix A (25 \times); B, General surface of mix B (50 \times); C, General surface with accumulated masses in case of mix C (50 \times); D, Rib structure of mix D (25 \times); E, General surface of mix E (50 \times); F, Surface showing restricted flow of the matrix of mix F (25 \times).

3.4. Flex fracture surface

In this test fracture results from the cyclic deformation and fatigue of the rubber vulcanizate. Figures 5A, 5B and 5C show the flex fracture surface of conventional mixes. Gradual addition of filler changes the fracture from ductile to brittle. EV mixes (Figures 5D–5G) show more cracks and less flow on the surface. Hence, flex endurance of EV mixes is poorer than that of conventional mixes.



(A)

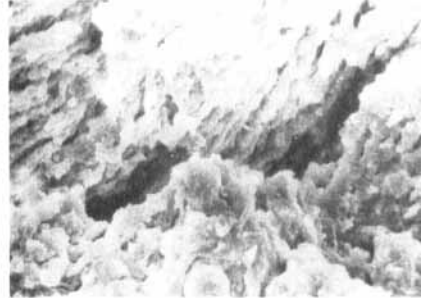

(B)

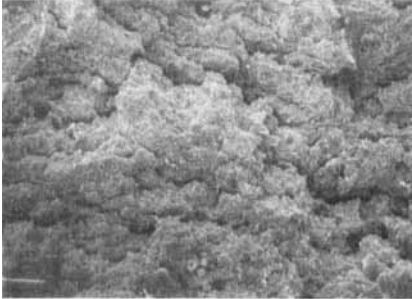

(C)

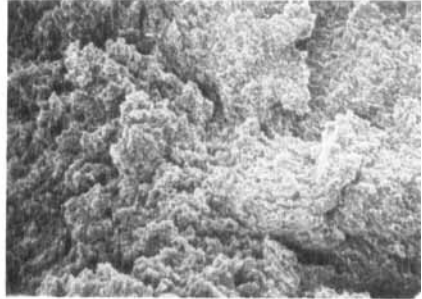

(D)

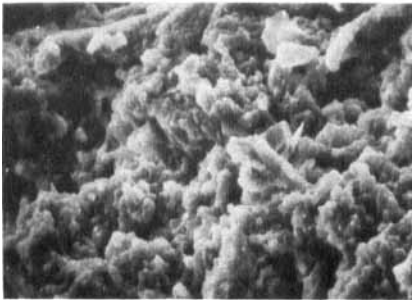

(E)

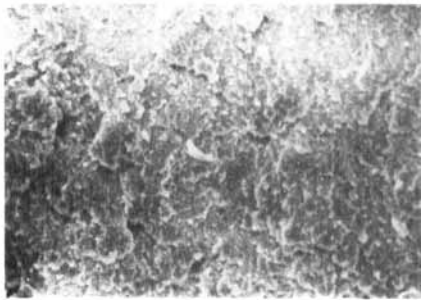

(F)

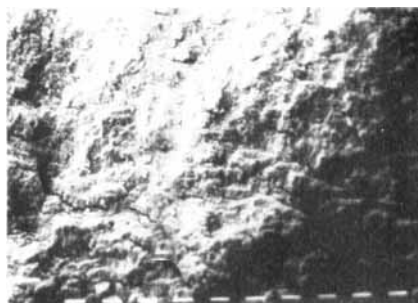

(G)

FIGURE 5 SEM photographs of flex fracture surfaces. A, General surface of mix A (50 \times); B, Surface showing transition from ductile to brittle fracture of mix B at higher magnification (400 \times); C, Brittle fracture of mix C (50 \times); D, General surface of mix D (50 \times); E, Flow of matrix at higher magnification of mix D (400 \times); F, Brittle fracture of mix E (100 \times); G, General surface of mix F (50 \times).

4. CONCLUSION

SEM studies show that gradual addition of filler changes the fracture surface. In the case of tensile and tear fracture, tear lines become shorter and curved on addition of HAF black filler. Flexing generates brittle fracture surface of the filled mix and ductile fracture surface of the gum mix. Structure of the rib in abrasion test changes on addition of filler. EV system in general gives identical information, but the flow of the matrix is restricted.

References

1. G. Kraus, *Reinforcement of Elastomers* (Interscience Publishers (a division of John Wiley and Sons), New York, 1965).
2. A. I. Medalia, *Proceedings of the International Conference on 'Structure-property relations of rubber'* at Indian Institute of Technology, Kharagpur, December 29–31, 1980, p. 13.
3. E. M. Dannenberg and J. J. Brennan, *Rubber Chem. Technol.*, **39**, 597 (1966).
4. M. L. Studebaker in G. Kraus (Ed.) *Reinforcement of Elastomers* (Interscience Publishers (a division of John Wiley and Sons) New York, 1965), p. 319.
5. A. Voet, *J. Polymer Sci., Macromolecular Reviews*, **15**, 327 (1980).
6. P. K. Pal, A. K. Bhowmick and S. K. De, *Rubber Chem. Technol.*, **55**, March/April, 1982.
7. A. K. Bhowmick, S. Basu and S. K. De, *Rubber Chem. Technol.*, **53**, 321 (1980).
8. A. K. Bhowmick, S. Basu and S. K. De, *J. Material Science*, **16**, 1654 (1981).
9. S. K. Chakraborty, A. K. Bhowmick, S. K. De and B. K. Dhindaw, *Rubber Chem. Technol.*, **55**, March/April, 1982.
10. N. M. Mathew, A. K. Bhowmick and S. K. De, *Rubber Chem. Technol.*, **55**, March/April, 1982.
11. R. Mukhopadhyay, S. K. De and S. N. Chakraborty, *Polymer*, **18**, 1243 (1977).
12. A. K. Bhowmick, G. B. Nando, S. Basu and S. K. De, *Rubber Chem. Technol.*, **53**, 327 (1980).
13. B. Saville and A. A. Watson, *Rubber Chem. Technol.*, **40**, 100 (1967).